

ENERGY SAVING

BEFORE

AFTER

- **20%**
Compared with
traditional inverter pump

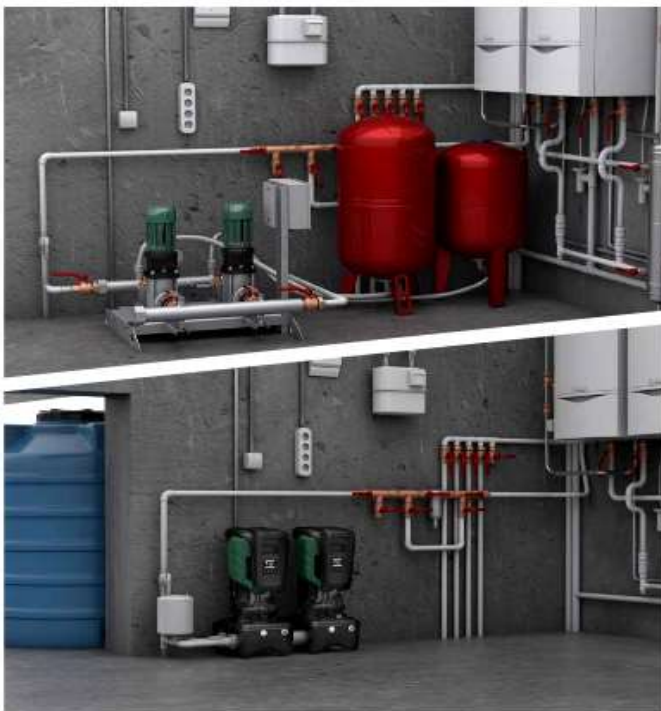

D+CONNECT
BUILT-IN

Available on the **Google play**

Download on the **App Store**



As quick as a "click"





PERFORMANCE CURVES

2023-01-12

Page 6 / 7

DAB PUMPS S.p.A.
Via Marco Polo, 14 - 35035 Mestrino (PD), Italy
Tel. +39 049 5125000 - Fax +39 049 5125950
www.dabpumps.com

	Receiver	From
Society Reference Address Phone Fax E-mail		DAB PUMPS OCEANIA FARMS OF THE FUTURE PROGRAM, 426 SOUTH GIPPSLAND HWY, DANDENONG SOUTH 1300 378 677 FOTF.AU@DABPUMPS.COM

2 ESYBOX MAX 60/120 M

Curve tolerance according to ISO 9906

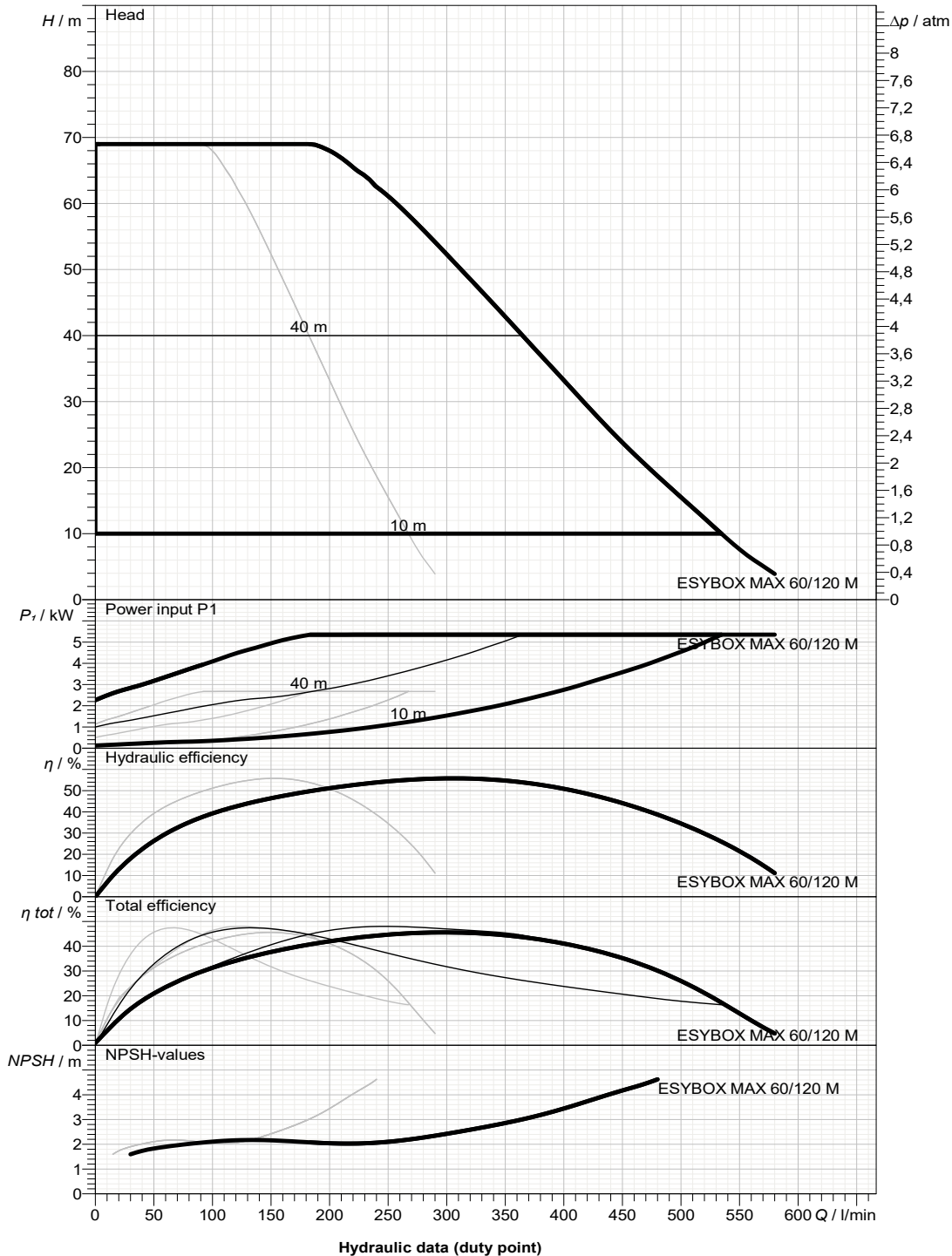

Suction side : 2" G 11,84 atm	Discharge side : 2" G 11,84 atm	Flow :	Head :	Rated speed : 5.240 1/min
MAIN_PROJECT_TITLE	BUSINESS_PROCESS_ID	OWNER_	ISSUE_DATE 2023-01-12	



DIMENSIONAL DRAWING

2023-01-12

Page 7 / 7

DAB PUMPS S.p.A.
Via Marco Polo, 14 - 35035 Mestrino (PD), Italy
Tel. +39 049 5125000 - Fax +39 049 5125950
www.dabpumps.com

Receiver

From

Society
Reference
Address
Phone
Fax
E-mail

DAB PUMPS OCEANIA
FARMS OF THE FUTURE PROGRAM,
426 SOUTH GIPPSLAND HWY, DANDENONG SOUTH
1300 378 677
FOTF.AU@DABPUMPS.COM

2 ESYBOX MAX 60/120 M

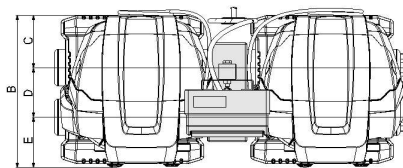
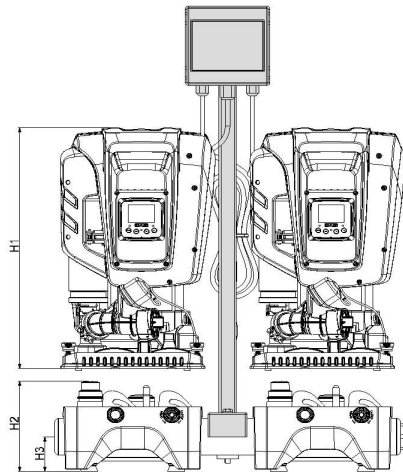
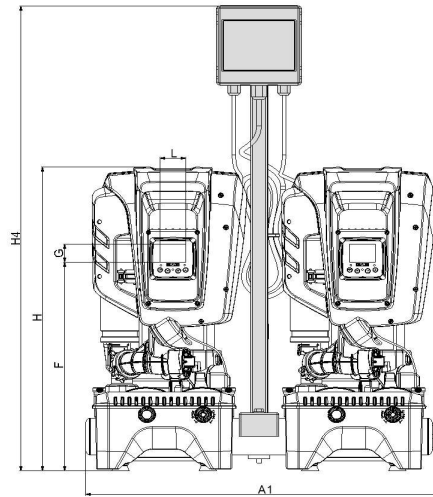

*Without the pillar kit and panel, do not consider the H4

Dimensions in mm						Pump connection
1	A1	811	H2	228		Suction 2" G 12 bar (1200 KPa)
2	B	384	H3	87		
3	C	131,8	H4	1.172		
4	D	124,5	L	59,5		
5	DNA	2"				Discharge 2" G 12 bar (1200 KPa)
6	DNM	2"				
7	E	127,7				
8	F	526				
9	G	45				
10	H	766				
11	H1	613				

MAIN_PROJECT_TITLE	BUSINESS_PROCESS_ID	OWNER_	ISSUE_DATE 2023-01-12
--------------------	---------------------	--------	---------------------------------